

Z3721/...

Mat.: 1.0718

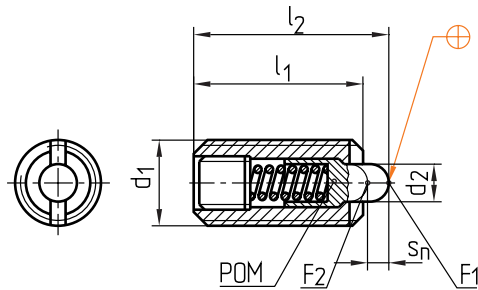

max. °C	d <sub>2</sub>	s <sub>n</sub>	F <sub>1</sub> [N]	F <sub>2</sub> [N]	l <sub>2</sub>	d <sub>1</sub>	l <sub>1</sub>	Nr./No.
100	1,5	1,2	5	12	16,5	<b>M 4</b>	<b>15</b>	Z3721/ 4x15
	2,4	1,8					<b>18</b>	5x18
	2,7	2					<b>20</b>	6x20
	3,5	2,4	9	28	25	<b>M 8</b>	<b>22</b>	8x22
	4						<b>M10</b>	10x22
	6	3,2	15	44	32	<b>M12</b>	<b>28</b>	12x28
	7,5	4	45	80	37	<b>M16</b>	<b>32</b>	16x32

Z373/...

Mat.: 1.0718

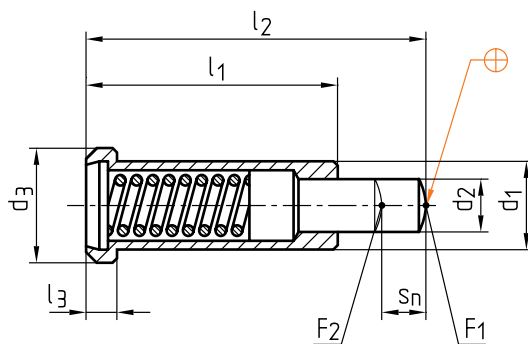

max. °C	d <sub>3</sub>	l <sub>3</sub>	d <sub>2</sub>	s <sub>n</sub>	F <sub>1</sub> [N]	F <sub>2</sub> [N]	l <sub>2</sub>	d <sub>1</sub>	l <sub>1</sub>	Nr./No.
250	13	4	5,9	5,5	45	100	40	<b>10</b>	<b>30</b>	Z373/10x30

This is trial version  
www.adultpdf.com